

BAG DECUFFER SEALER HIGH END DS-31-HE

The DS-31-HE automatically decuffs, stretches and heat seals the bag. Designed to handle crates and for high cleanability and crate handling, the bag sealer meets the needs of the high demanding industries with **reduced energy consumption**.

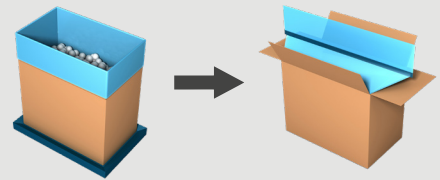

FOR HIGH
DEMANDING
APPLICATIONS

Protect your product

- **Shelf life extension** thanks to hermetic heat sealing, vacuum packing and gas flushing.
- **Two double sided impulse heat seals.**
- **High food safety:** minimal moving parts above the filled case.

Easy to use, easy to clean

- **Elimination of operator mistakes** thanks to the fully automatic format change.
- Random case height modus.
- **Tool-free changeover of vacuum probe** for cleaning.
- Special cleaning mode to **hose down conveyors**.

TECHNICAL SPECIFICATIONS DS-31-HE

Vacuumize and gas flush installation

- Tool-free exchangeable vacuum probe to:
 - Remove excess air
 - Vacuumize until a set under pressure is reached
 - Vacuumize and gas flush for shelf life extension

A perfect hermetic seal

- Full and optimised decuffing with vacuum decuffer
- Integrated bag detection with servo motor driven stretcher plates.
- Two double sided impulse heat seals with upper and lower clamping device to keep film stress free during sealing.

Equipped with

- HMI colour touch panel: Intuitive 15" HMI for easy operation
- Multicolour warming light
- Remote Access Point

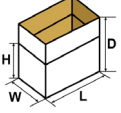
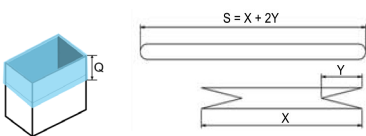
CONTAINER SPECIFICATIONS (For other dimensions or container types, please contact Pattyn)	
Type	Cases, boxes, trays, crates
Range (L x W x H // D) mm	Standard mono footprint (LxW) /variable heights
	Min. 280 (L) x 240 (W) x 190 (H) Max. 600 (L) x 400 (W) // 650 (D)
	Outside dimensions
If S > 900 mm or when running crates or trays: optional gusset sealing is necessary. (S = half of the circumference of the bag)	
FILM SPECIFICATIONS	
Type	PE based
Thickness	15 µm – 70 µm
	X = L + 15
	Y = (W + 25) / 2
	S = max 900 mm
	L + W + 40 ≤ S ≤ L + W + 90
	140 ≤ Q ≤ 180 mm
OUTPUT AND CONSUMPTION	
Output without vacuum and gas flush installation	Up to 10 c/min Up to 8 c/min for SL
Installed power	11 kW
Voltage	3 x 400 V + N + E / 50 Hz
Air supply	6 bar / 1" min
Air consumption	55 NL / cycle
Weight	1250 kg
OPTIONS (More options are available, please contact Pattyn)	
Vacuum installation	Vacuum & gas flush installation
Multi-footprint / variable case heights	
Hose down execution	
Gusset sealing for crates and carton trays or when S > 900 mm	
Perforation module for full or partial perforation below the seal for easy opening	



Vacuum decuffer hooks



Bag stretching with integrated decuffer control

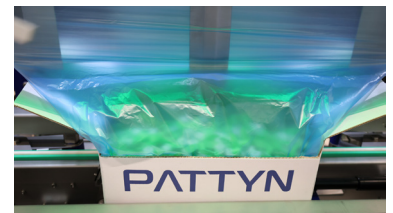

Vacuumizing & gas flushing



Your product 100% protected

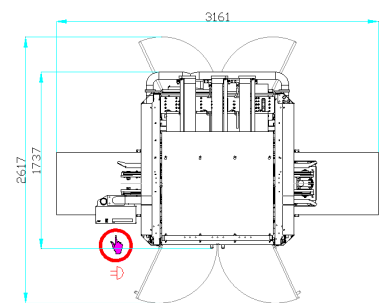

Machine height 2621 mm

Pattyn Belgium
Industriepark 'Blauwe Toren'
Hoge Hul 2, 8000 Brugge - Belgium

T +32 (0) 50 450 480
info@pattyn.com
www.pattyn.com



The description, pictures and information given have an indicative value. We reserve the right to make changes without notice. Information and content is property of Pattyn. For customised executions please contact Pattyn. DS-31-HE 2021 - V01

PATTYN[®]

Turnkey solutions for industrial packaging.