

WEIGHFILLER FOR BUTTER BVL-42

The BVL is the most hygienic and flexible weighfiller for any type of butter.

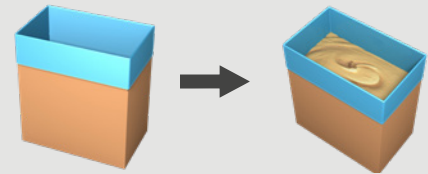

ACCURACY
FLEXIBILITY
HYGIENE

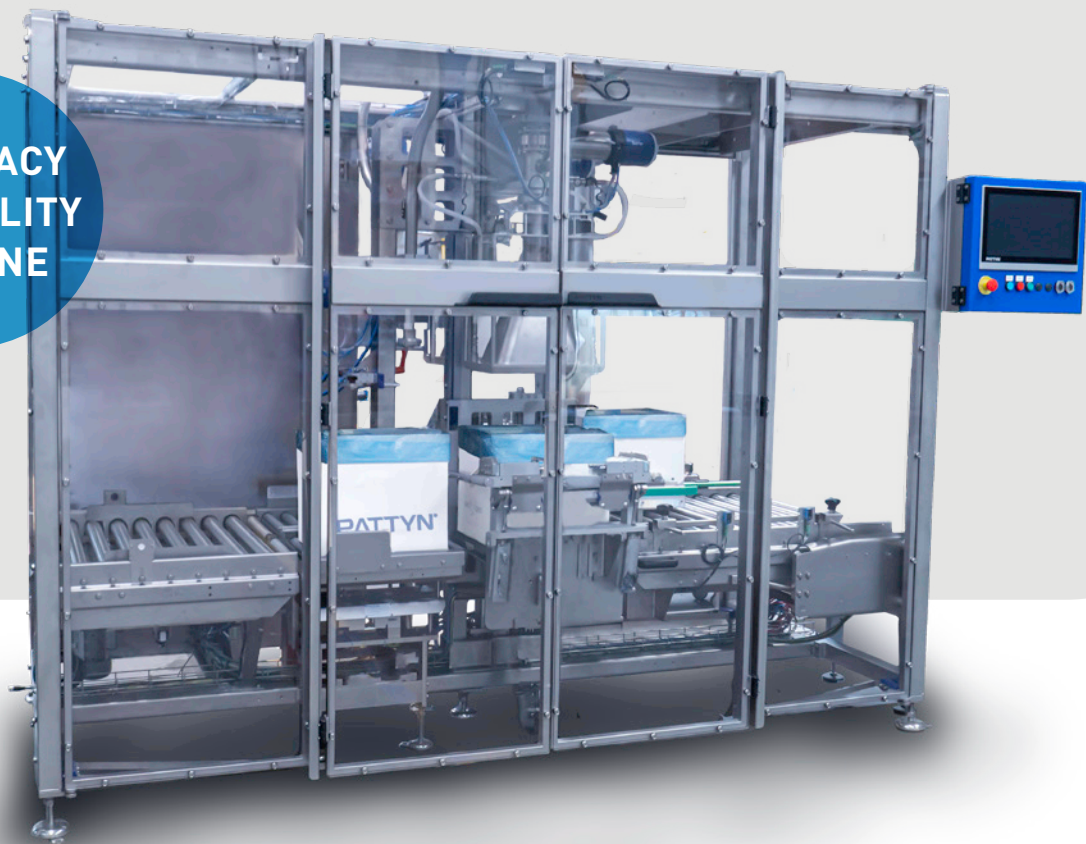

For any butter texture

- Auto-adaptable to all butter textures
- Flexible changeover between box footprints
- From 5 to 25 kg
- Accuracy 5gr

Minimize your product giveaway

- Fast and accurate butter filling
- Standard CIP cleaning
- High speed, up to 7.5 ton / hour
- Auto weight correction

TECHNICAL SPECIFICATIONS

The most flexible butter filler on the market

- 60 years of experience in weighing technology
- Two step filling: volumetric main filling and fine dosing station to assure a perfect balance of speed & accuracy.
- Perfect control of product flow

Hygienic design

- Direct filling without compensator / piston
- Tiltable infeed conveyor for easy cleaning accessibility
- HACCP guarding for maximum food safety

Standard equipped with:

- CIP cleaning system
- Full stainless steel design
- 15" HMI for easy operation
- Remote Access Point

CONTAINER SPECIFICATIONS [For other dimensions, please contact Pattyn]	
Type	Cases
Range case, crate (L x W // D) mm	Min. 260 (L) x 120 (W) // 240 (D) Max. 400 (L) x 300 (W) // 420 (D) Condition: H x 1000 / (L x W) > 2
OUTPUT AND CONSUMPTION	
Output BVL-42	5 cases / min - max 7,5 ton/hour
Accuracy	5g* standard deviation (depending on product flow & consistency)
Product filling temperature	12-16°C
Installed power	1,5 kW
Voltage	3 x 400 V + N + E / 50 Hz
Air supply	6 bar / 1/2" min
Air consumption	20 NI/cycle
Weight	1750 kg
OPTIONS (More options are available, please contact Pattyn)	
Data communication system	
Extra filling head per footprint	
Tare weight correction for every case	



Filling head



Tiltable infeed conveyor for easy cleaning



15" HMI

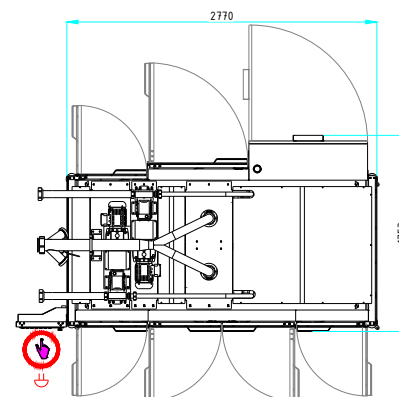

Machine height 2575 mm

Pattyn North America Inc.
N56W24660 N. Corporate Circle
Sussex, WI 53089 - U.S.A.

Ph + 1 262-966-0300
Fax +1 262-966-0312
SalesUsa@pattyn.com



The description, pictures and information given have an indicative value. We reserve the right to make changes without notice. Information and content is property of Pattyn. For customised executions please contact Pattyn. BVL-42 2023-V01