

WEIGHFILLER AVL-42/44

The AVL-42/44 is the most accurate weighfiller with two or four filling valves and scales, specially designed for the filling of semi-liquids such as: edible oils & fats, cocoa mass or butter, processed cheese, fondant sugar, mayonnaise,...

The hygienic design of the AVL-42 and completely closed HACCP guarding with swing doors offers maximum food safety.

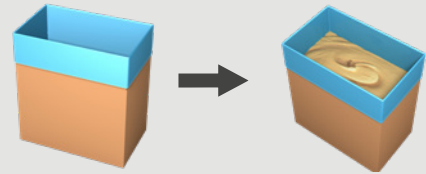

COMBINE
HIGH SPEED &
ACCURACY WITH
MAXIMUM CLEANING
ACCESSIBILITY



AVL-42 with two filling heads



Minimize your product giveaway

- The **fastest and most accurate** semi-liquid filler on the market.
- Specially designed for a wide range of different edible oils & fats.

Maximize your productivity

- High speed, up to 15 cases / minute (for AVL-44).
- Designed for **maximum cleaning accessibility**.
- **Wide range of containers:** pails, tins, cases, crates.
- **15" HMI** to facilitate operator convenience.

 Watch our videos
at pattyn.com

TECHNICAL SPECIFICATIONS

The most accurate semi-liquid filler on the market

- 60 years of experience in weighing technology has been applied in the new generation weigh controller.
- Specially designed **ultra light weight scales**.
- **Standard double jacketed** and **90° curved valves** to ensure a turbulent-free product flow.
- **Fast / slow system** and **selfregulated valve closing** for automatic after-fall correction.
- **Valves adjustable** in height for minimal after-fall, increased accuracy and higher speed

Scales fixed to the floor

- Isolated and vibration-free position of the scales allows maximum accuracy.

Maximum cleaning accessibility

- Tilttable infeed conveyor for easy cleaning

Standard equipped with:

- 15" HMI for easy operation
- Remote access point (one per line)
- In- and outfeed conveyor
- HACCP guarding with swing doors

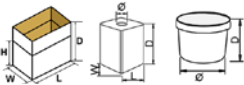
CONTAINER SPECIFICATIONS (For other dimensions, please contact Pattyn)	
Type	Cases, tins, pails, crates
Range case, crate (L x W // D) inches	Min. 12" (L) x 8" (W) // 8" (D) Max. 16" (L) x 12,6" (W) // 19 1/2" (D)
Range tins (L x W // D, Ø opening) inches	Min. 8" (L) x 8" (W) // 8" (D) Ø 1 9/16" Max. 15 3/4" (L) x 12,6" (W) // 19 1/2" (D)
Range pails (diam x D) inches	Min. Ø 8" x 8" (D) Max. Ø 12,6" x 19 1/2" (D)
	Outside dimensions
OUTPUT AND CONSUMPTION	
Output AVL-42	Mode 1: max 10 c/min, 26,400 lbs/hr (12 ton/hour) (*) Tare weight correction for every case Mode 2: max 12 c/min, 26,400 lbs/hr (12 ton/hour) (*) Every 10 cases : tare weight correction
Output AVL-44	Up to 15 c/min, 40,000 lbs/hr (18 ton/hour) (*)
(*) For the output of pails, tins and other containers, please contact Pattyn.	
Maximum average giveaway	+ 0.106 oz per case
Standard deviation	+/- 0.5 oz
Accuracy	+/- 1.5 oz or better
Installed power	1,5 kW
Voltage	3 x 480V + E / 60 Hz
Air supply	90 PSI, (1/2" min)
Air consumption	0.7 ft ³ / cycle
Weight	3307 lbs
OPTIONS (More options are available, please contact Pattyn)	
Drip catchers under each valve	Anti-splash jacketed device
CIP cleaning system and software	Special valves depending on the product
Small adaptations for pails, crates and tins	Statistic software module
Product shakers	
Motor driven height regulation valves	
Filling valve DN32 for tin opening diameter 1.6" - 3.5"	



New generation weigh controller



90° curved valve with drip catcher



Fast and slow filling



Tilttable infeed conveyor for easy cleaning



15" HMI

AVL-42, standard with in- and outfeed conveyor

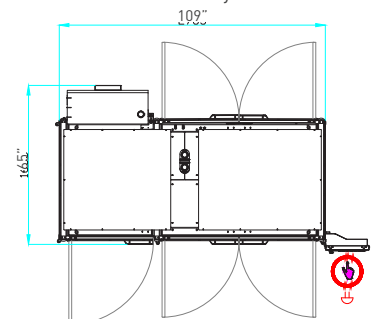

Machine height 84"

Pattyn North America Inc.
N56W24660 N. Corporate Circle
Sussex, WI 53089 - U.S.A

Ph +1 262-966-0300
Fax +1 262-966-0312
SalesUsa@pattyn.com



The description, pictures and information given have an indicative value. We reserve the right to make changes without notice. Information and content is property of Pattyn. For customized executions please contact Pattyn. AVL-42/44 2021 - V01

PATTYN[®]

Turnkey solutions for industrial packaging.