

PATTYN®

LINEAR VIBRATORY WEIGHFILLER LVF-34A/B

The LVF-34A/B linear vibratory filler with one or two heads offers the most suitable solution to weigh and fill all kinds of **diced & sliced IQF fruits and vegetables, dried non sticky fruits, candy, ...**

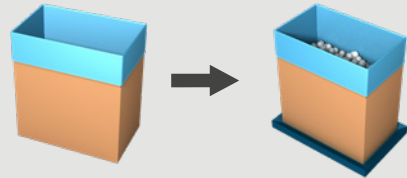

COMBINE
CONVENIENCE &
ACCURACY

One head vibratory filler
LVF-34A

Easy to use Easy to clean

- Your ideal solution for **easy weigh filling** up to 10 c/min.
- Hygienic design.
- **Quick & easy cleaning** for minimum down-time.
- Filling in **weigh hopper**.
- Integrated **bag holding device**.

 Watch our videos
at pattyn.com

TECHNICAL SPECIFICATIONS LVF-34A/B

Easy weigh filling

- Linear filler with 3 vibrating pans: one for taking the product out of the bunker, one big pan for coarse filling and one small pan for fine dosing.
- Constant product flow during fine filling.
- Product overflow from small vibrating pan to coarse filling pan.

Net filling in weigh hopper

- High line speed, no down time during box transfer.
- Afterfall height for fine filling is low.

Easy to clean

- Weigh hopper with quick release reduces your cleaning time and cleaning cost.

For dry bulk products up to 2.4 x 2.4 x 2.4 inches

- IQF fruits & vegetables
- Dried non-sticky fruits
- Candy
- ...

Standard equipped with

- Colour touch panel for easy operation
- Access point for remote support (one per line)



Coarse and fine filling

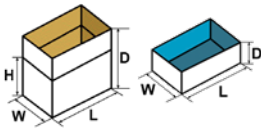

Filling in weigh hopper

CONTAINER SPECIFICATIONS (For other dimensions, please contact Pattyn)	
Type	Cases, trays, plastic crates...
Range (L x W // D) mm	Min. 12" (L) x 8" (W) // 4" (D) Max. 31 1/2" (L) x 19 1/2" (W) // 25 1/2" (D)
	Outside dimensions
OUTPUT AND CONSUMPTION	
Output	LVF-34A one head vibratory filler Up to 6 c/m (depending on product and weight) LVF-34B two head vibratory filler Up to 10 c/m (depending on product and weight)
Product diameter size	Max. 2.4 x 2.4 x 2.4 inches
Installed power	LVF-34A: 5 kW LVF-34B: 9 kW
Voltage	3 x 480V + E / 60 Hz
Air supply	90 PSI, (1/8" min)
Air consumption	0.14 ft ³ /cycle
Weight	One head filler: 1323 lbs Two head filler: 2205 lbs
OPTIONS (More options are available, please contact Pattyn)	
Dimple plate execution	
Heating element to prevent condensation	

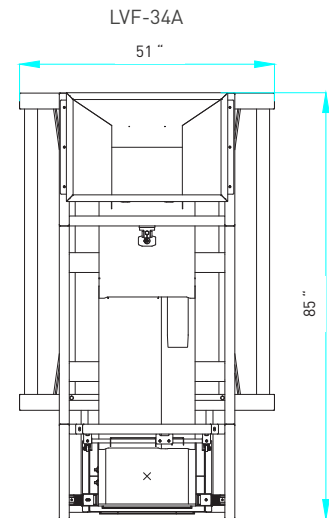

Machine height 123 inches

Machine height as reference only, depending on case dimensions.

**Accuracy depends on the product and capacity.
For more details or specific requirements, please contact us.**

Pattyn North America Inc.
N76 W30500 County Road Vv
Hartland, WI. 53029 - U.S.A

Ph +1 262-966-0300
Fax +1 262-966-0312
SalesUsa@pattyn.com



The description, pictures and information given have an indicative value. We reserve the right to make changes without notice. Information and content is property of Pattyn. For customized executions please contact Pattyn. LVF-34A/B 2021 - V01

PATTYN®

Turnkey solutions for industrial packaging.